



CITY OF ZEPHYRHILLS PUBLIC WORKS DESIGN MANUAL MINIMUM STANDARDS

All street improvements, whether public or private, shall be designed and constructed to conform to the requirements of the Florida Department of Transportation Standards Specifications for Road and Bridge Construction, latest edition and amendments, the State of Florida Manual of Uniform Standards for Design, Construction, and Maintenance of Streets and Highways.

SECTION 1. GENERAL REQUIREMENTS

All streets within subdivisions shall be classified as private streets. A request to dedicate a street to the public shall be approved by the city council.

Other types of construction and/or materials may be utilized for the base and surface of the roadway if equal or greater strength requirements are met, and if approved by the Public Works Director.

Street name and regulatory signs shall be provided by the developer and shall be of comparable size, design, and quality to street signs used by the City. Street name signs shall include a green background with white letters and border. All street name signs on *private roads* shall be standard D3 street name signs with the colors reversed (white background with green letters and borders). At intersections with city maintained streets, the city street shall be green background with white letters and border. All street signs shall be compliant with the latest Manual on Uniform Traffic Control Devices (MUTCD) Standards.

SECTION 2. ROADWAY SURFACES

Roadway surfaces shall be standard FDOT asphaltic concrete mixes. Any other surfaces shall be approved by the Public Works Director.

Speed humps or other similar “traffic calming devices” shall not be installed on any public road or street within the City of Zephyrhills.

Road-side memorials on or along public right-of-way within the City of Zephyrhills shall be prohibited.

SECTION 3. MINIMUM PAVEMENT THICKNESS

Residential streets shall be designed by a Professional Engineer that is licensed in the State of Florida.

If any street is to be dedicated to the public it shall have a minimum of two (2) inches of asphalt.

SECTION 4. MINIMUM LANE WIDTH / RIGHT-OF-WAY WIDTH

The specifications contained in this subsection are intended as minimum specifications. All local streets shall be a minimum of ten (10) feet and collector and arterial lanes shall have a minimum width of twelve (12) feet.

Local streets shall have a minimum of sixty (60) feet of right-of-way. Collector streets shall have a minimum of eighty (80) feet. Arterial streets shall have a minimum of one-hundred and twenty (120) feet.

SECTION 5. PEDESTRIAN ROUTES, SIDEWALKS, & BIKE PATHS

The construction of all sidewalks shall comply with the following minimum criteria:

- A.** All sidewalk construction shall meet all ADA requirements.
- B.** 3000 P.S.I. concrete shall be required.
- C.** Concrete shall be a minimum of four (4) inches thick except which cross driveways shall be six (6) inches thick and be reinforced with 6 inch by 6 inch x 10 gauge wire mesh or equal material.
- D.** Sidewalks shall be a minimum of five (5) feet in width.
- E.** Expansion material will be placed on each side of the sidewalk thru concrete driveways.
- F.** Sidewalks shall be placed on both sides of the street and bike paths shall be placed on all collector and arterial streets.
- G.** ADA ramps shall be designed and constructed using concrete (no pavers or bricks within ramp area).
- H.** No drainage grates within pedestrian / accessible routes or within designated crosswalk.
- I.** Multi-use trails: Proposed developments shall be responsible for the construction of multi-purpose trail as specified herein and as shown on the approved multi-use trail master plan. Construction of the trail will be in lieu of required sidewalks. Trail design & surface shall be approved by the Public Works Director. (see figure 10 for minimum dimensions)

SECTION 6. STORMWATER DESIGN

All development shall secure a permit from the Southwest Florida Water Management District.

The stormwater management plan shall be designed to meet a twenty-five (25) year

frequency storm with a twenty-four (24) hour duration. This is a minimum event as the developer must meet any water management, state or federal standards. Duplex development shall be considered commercial property and shall meet all state and local standards set forth as commercial property. All development in basins of special concern by ordinance shall meet the standards set forth in the ordinance. Any street, alley, or platted right-of-way owned and maintained by the city, county or state shall be considered exempt as having an approved master storm water plan per ordinance 941-05, Re: Basins of special concern – provided the street, alley or platted right-of-way was owned or maintained by the city, county or state prior to January 9, 2006.

The City will accept no detention/retention ponds or any other drainage easement areas. All detention/retention and drainage areas shall be maintained by a Homeowners Association.

SECTION 7. STREET LIGHTING

All street lights shall be maintained by a Homeowners Association.

SECTION 8. DRIVEWAYS

A. PERMITTING Driveway permits are necessary when the driveway installation, replacement, or addition encroaches into the public right-of-way, which extends beyond the homeowner's private property.

A permit grants the property owner permission to construct a driveway on public right-of-way. The property owner shall be responsible for maintenance of the driveway (See figure 1.)

Permit applications are available by contacting the city's building department office located at 5335 8th Street Zephyrhills, FL 33542. Telephone: 813.780.0020.

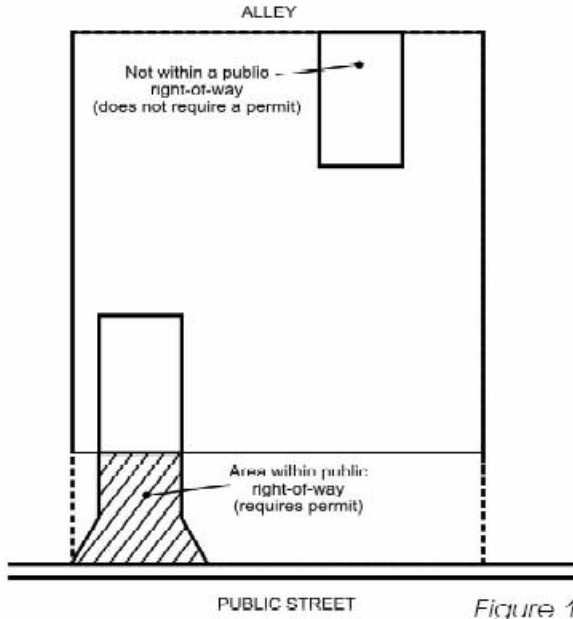

B. SIDE SET BACKS Driveways shall meet a minimum side yard setback of three (3) feet within the public right-of-way. The driveway may be located closer than three (3) feet to the property line, but only within the boundary of the homeowner’s private

C. DRIVEWAY WIDTH The minimum width for a driveway shall be ten (10) feet and the maximum width shall be twenty (20) feet. A parking pad no wider than (10) feet may be installed contiguous to an approved driveway provided that the driveway, as it crosses the property line, shall not exceed twenty (20) feet. (See figure 3.)

D. DRIVEWAY LENGTH The minimum length for a driveway shall be nineteen (19) feet within the boundary of the homeowner’s private property. This minimum length requirement is necessary to prevent vehicles from overhanging into the public right-of-way. (See figure 5.) Note: Circular driveways shall be prohibited unless approved by the Public Works Director.

E. IMPERVIOUS SURFACE RATIO Impervious surface coverage is measured in square feet and as a percentage of lot area. The maximum impervious surface ratio allowed within the required front yard setback on a standard lot is forty-five (45) percent. The maximum surface ratio allowed within the required front and street side yard setback on corner lots is twenty-five (25) percent. Impervious surface calculations shall include any patios or walkways that are not included on the proposed or revised driveway. (See figures 6 & 7.)

F. TRIANGULAR FLARE Each driveway, when located within the public-right-of-way shall contain triangular driveway flares at the intersection of the driveway and the public roadway. Driveway triangular flares shall measure three (3) feet in width and seven (7) feet in length (See figure 8.)

G. VISIBILITY TRIANGLE Driveways may encroach into the visibility triangle within the public right-of-way, but driveways cannot be permitted within the visibility

H. PEDESTRIAN ROUTES If an existing designated pedestrian route (sidewalk) intersects with a proposed or revised driveway, the driveway portion that aligns with the pedestrian route / sidewalk shall be constructed to ADA standards and shall include an expansion joint on both sides of the sidewalk. These expansion joints separate the sidewalk from

the driveway in the event of repairs or replacement of the sidewalk.

I. DRIVEWAY MATERIALS The portion of the driveway located within the public right-of-way shall be constructed of concrete or asphalt. Any other type of material shall be approved by the Public Works Director. Concrete driveways shall be a minimum of six (6) inches in depth. Asphalt driveways shall include a lime rock base no less than six (6) inches in depth and the asphalt shall be a minimum thickness of one-and-one-half (1-1/2") inches in depth.

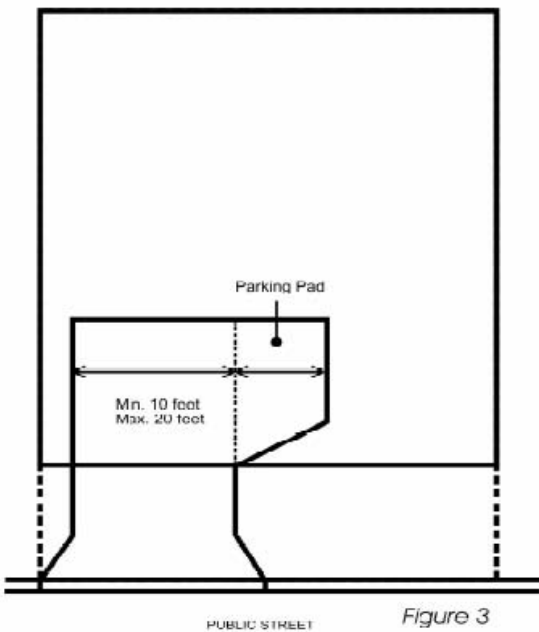
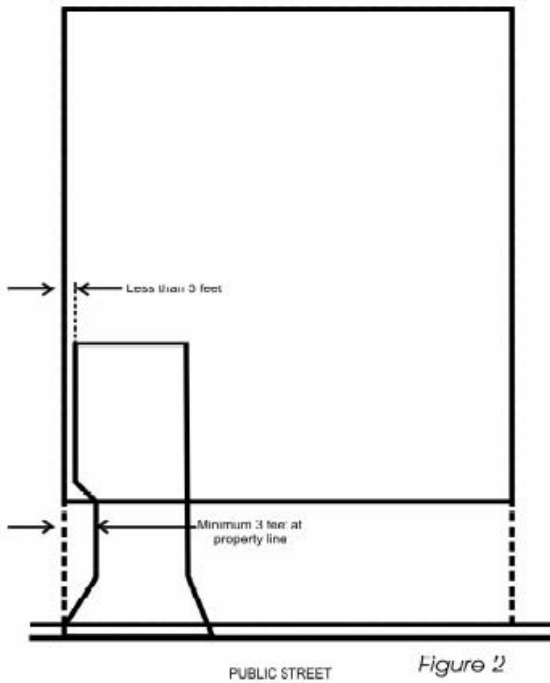

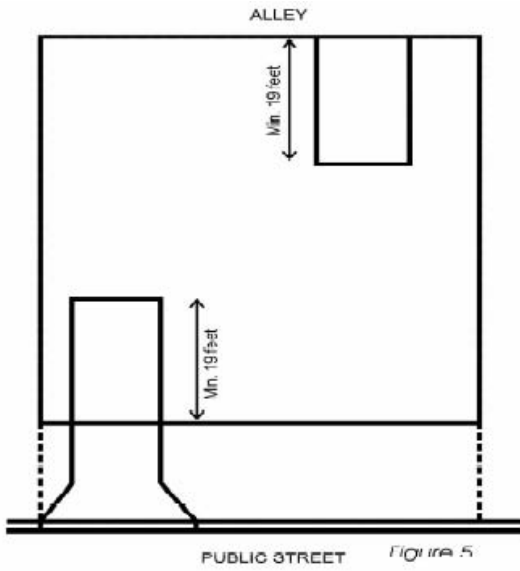

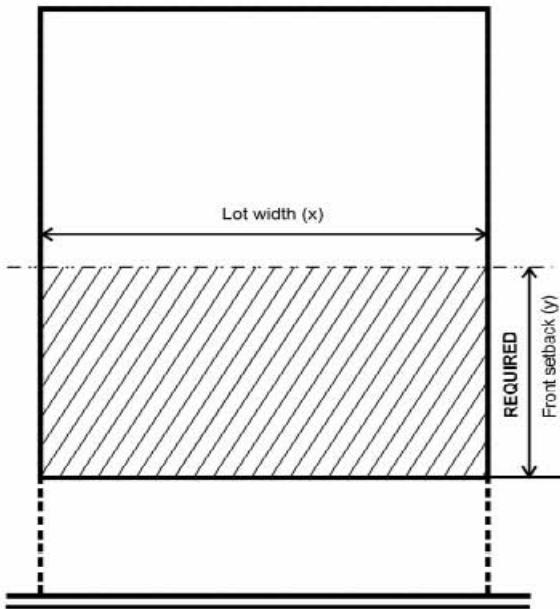

Figure 6

$(x) \times (y) = c$
 $(c) \times 0.45 = z$
 $z =$ maximum impervious surface square footage allowed within the required front yard setback

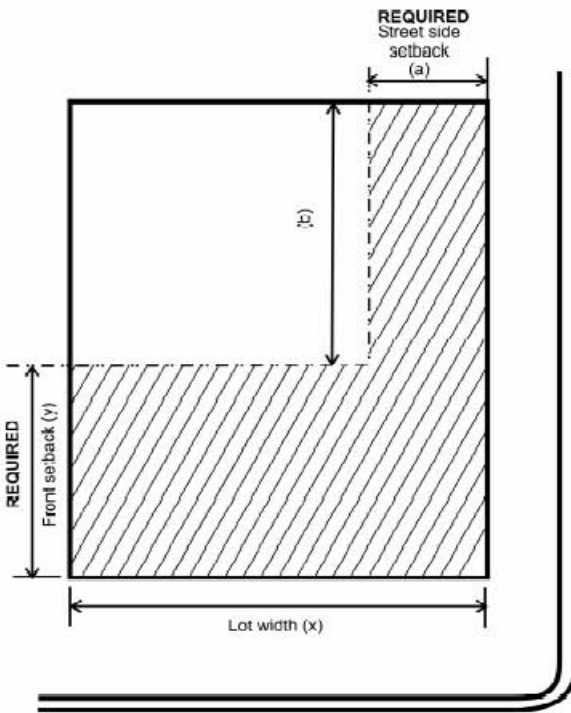
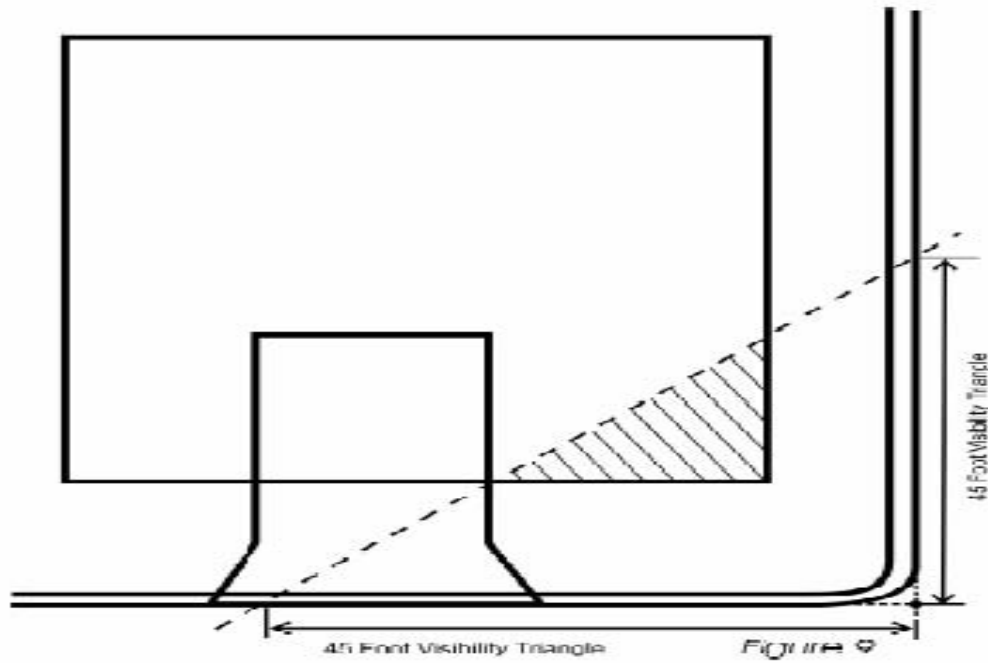
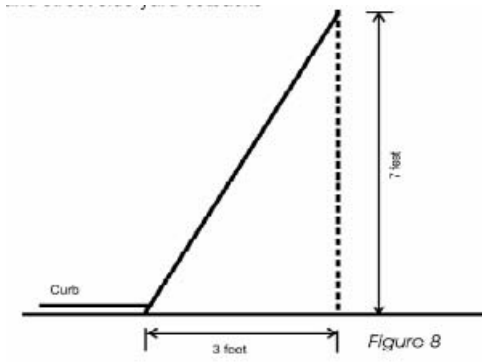
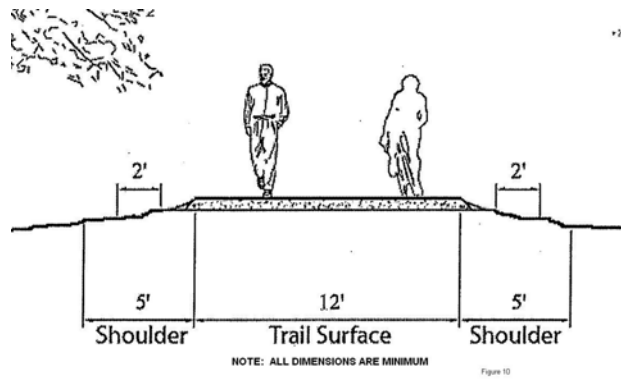

Figure 7

$(x) \times (y) = c$
 $(a) \times (b) = d$
 $(c) + (d) = m$
 $(m) \times 0.25 = z$
 $z =$ maximum impervious surface square footage allowed within the required front and street side yard setbacks



Note: The City Of Zephyrhills reserves the right to revise these minimum standards when deemed necessary.



SECTION 9. DUMPSTER ENCLOSURES

The construction of all dumpster enclosures shall comply with the following minimum criteria:

A. All dumpster enclosures shall be permitted and include a detailed site plan – the site plan shall show the proposed location on the site to include any existing overhead utilities.

B. The dumpster enclosure shall be designed and constructed as per the specifications contained herein.

C. The dumpster enclosures shall be “field located” **PRIOR** to construction. The contractor shall request a mandatory “field locate” inspection by calling the sanitation department at 813.780.0022. Failure to request a “field locate” may result in relocation at the owner’s / contractor’s expense.

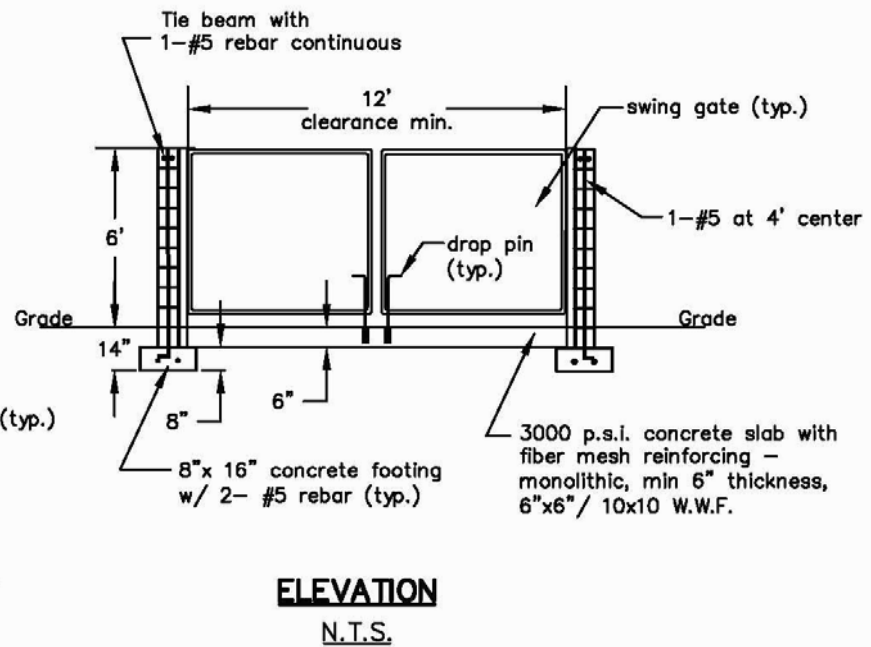
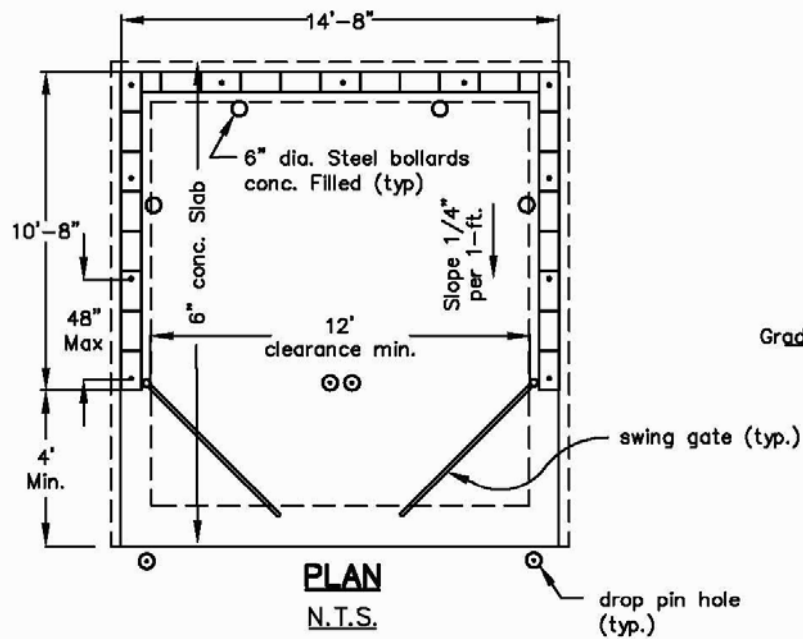

				CITY OF ZEPHYRHILLS, FLORIDA PUBLIC WORKS ADMINISTRATION	
				DRAWN BY	DATE
				CHECKED BY	INDEX NO.
				DESIGNED BY	
REV.	DATE	DESCRIPTION	APP.		
					1 OF 3

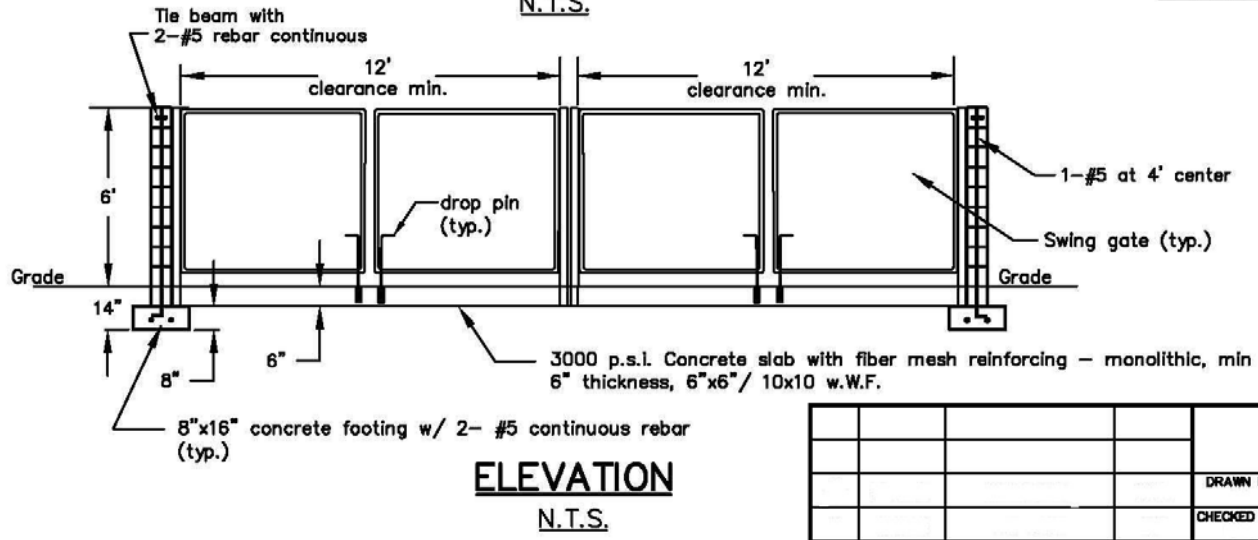
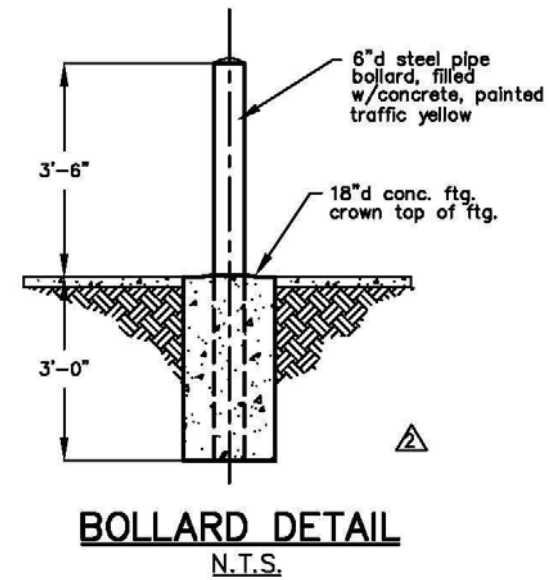
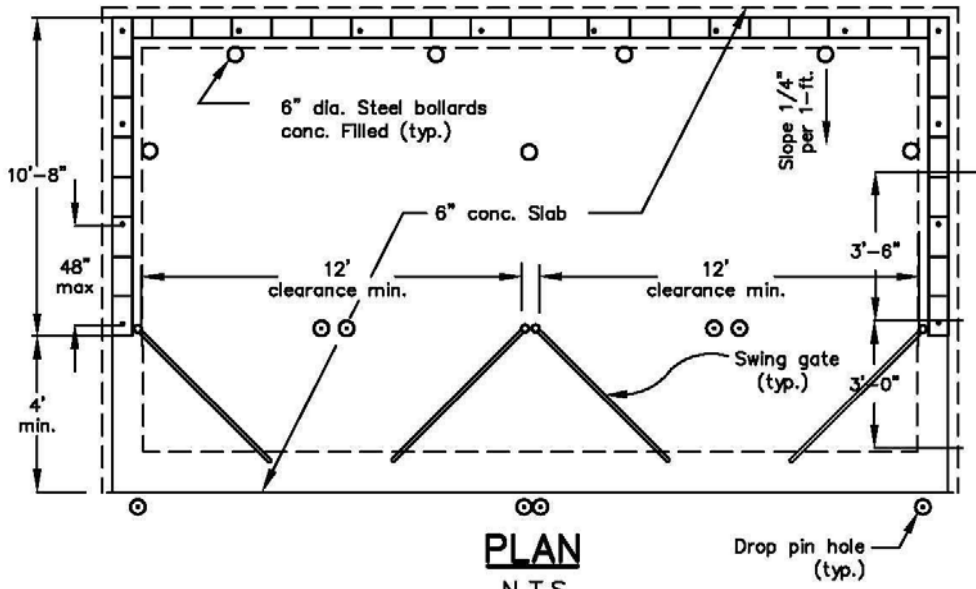

				CITY OF ZEPHYRHILLS, FLORIDA PUBLIC WORKS ADMINISTRATION	
		DRAWN BY		DATE	
		CHECKED BY		DUMPSTER ENCLOSURE DOUBLE	
		DESIGNED BY		INDEX NO.	
REV.	DATE	DESCRIPTION	APP.	2 OF 3	

NOTES:

- 1.) WALLS
New construction: maximum 6'-0" high and constructed of concrete block (8"x8"x16"). Materials used should be consistent with those used in the construction of and architectural style of the principal building.
- 2.) FOOTINGS
8"x16" concrete w/ 2 - #5 continuous rebar embedded.
- 3.) CONCRETE SLAB
Monolithic, min. 6" thickness w/ imbedded 6"x6" / 10x10 welded wire fabric (W.W.F.), 3000 p.s.i. with fiber mesh reinforcing.
- 4.) CONCRETE FILLED CELLS
With 1 - #5 vertical rebar tied to footer steel at each corner and every 4' o.c.
- 5.) GATES
Constructed of min. 1-1/2" diameter galvanized tubular steel w/privacy-type slats inserted in galvanized steel mesh fabric, hinge-mounted on min. 3" diameter galvanized steel post. (Gates and post constructed and installed per applicable building code by licensed fence constructor).
- 6.) DROP PIN
1/2" dia. 18" long metal rod gate latch. Provide 3/4" dia. hole 6" into concrete for rods. In asphalt provide a 3/4" p.v.c. sleeve, 6" long, or equal.
- 7.) SOIL
Soil bearing capacity to be at least 2,500 p.s.f.
- 8.) BOLLARD
3'-6" high, 6" diameter steel pipe bollard with concrete, painted traffic yellow, imbedded 3'-0" deep in 18" concrete foundation. (See Detail)

CONCRETE MASONRY WALL CONSTRUCTION

Materials, construction and quality control of masonry shall be in accordance with applicable Florida Building Code / Local Code Minimum Standards.

1. All reinforcing steel shall be deformed bars conforming to ASTM A-615, Grade 60. Vertical reinforcement shall be placed in the center of the masonry cell, and shall be held in position at the top and bottom.
2. If a slab dowel does not line-up with a vertical core, it shall not be sloped more than one horizontal in six verticals (1:6).
3. Horizontal wall reinforcement shall be standard truss type DUR-O-Wall (or equivalent) at 16" o.c.
4. Hollow Load – bearing Concrete Masonry Units shall be normal weight conforming to ASTM C-90, with a minimum compressive strength of 1,900 p.s.i.
5. Mortar shall be type M or S, in accordance with ASTM C-270. Place all masonry in running bond with 3/8" mortar joints. Provide complete coverage face shell mortar bedding, horizontal and vertical.
6. Coarse grout shall conform to ASTM C-476, with a maximum aggregate size of 3/8", 8" to 10" slump, and a minimum compressive strength of 2,500 p.s.i. at 28 days.
7. Minimum 3" x 3" clean-out holes (saw-cut) are required at the bottom course of all cells to verify grout placement. Clean-outs shall be sealed after masonry inspection – provided in accordance with ACI 531-4.6, and before grouting.
8. Prior to grouting, the grout space shall be clean, with no mortar projections greater than 1/2", mortar droppings or other foreign material. All cells shall be in vertical alignment, and shall solidly be filled with coarse grout as specified.
9. During placing, grout shall be consolidated with flexible cable vibrator. First grout pour shall be stopped a minimum of 1-1/2" below the top of the middle bond beam masonry.